

STATE OF NORTH CAROLINA  
**DEPARTMENT OF TRANSPORTATION**

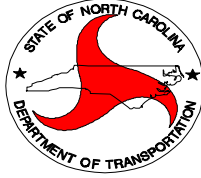

DIVISION 11 DISTRICT 2

**CONTRACT PROPOSAL**

**SMALL BUSINESS ENTERPRISE PROJECT**

WBS ELEMENT NUMBER: To Be Assigned CONTRACT: 11-02-514  
ROUTE: Various COUNTY: Watauga  
DESCRIPTION: Long-Arm Mowing on Various Routes upon request in Watauga County, North Carolina

BID OPENING: January 17, 2013 @ 10:00 AM

**NOTICE:**

ALL BIDDERS SHALL COMPLY WITH ALL APPLICABLE LAWS REGULATING THE PRACTICE OF GENERAL CONTRACTING AS CONTAINED IN CHAPTER 87 OF THE GENERAL STATUTES OF NORTH CAROLINA WHICH REQUIRES THE BIDDER TO BE LICENSED BY THE N.C. LICENSING BOARD FOR CONTRACTORS WHEN BIDDING ON ANY NON-FEDERAL AID PROJECT WHERE THE BID IS \$30,000 OR MORE, EXCEPT FOR CERTAIN SPECIALTY WORK AS DETERMINED BY THE LICENSING BOARD OR SBE PROJECT. BIDDERS SHALL ALSO COMPLY WITH ALL OTHER APPLICABLE LAWS REGULATING THE PRACTICES OF ELECTRICAL, PLUMBING, HEATING AND AIR CONDITIONING AND REFRIGERATION CONTRACTING AS CONTAINED IN CHAPTER 87 OF THE GENERAL STATUTES OF NORTH CAROLINA.

NAME OF BIDDER

N.C. CONTRACTOR'S LICENSE NUMBER

ADDRESS OF BIDDER

**RETURN BIDS TO:**

QUOTE NO: 11-02-514 –WATAUGA COUNTY LONG-ARM MOWING  
N.C. DEPARTMENT OF TRANSPORTATION  
JOE L. LAWS, PE, DIVISION PROJECT MANAGER  
801 STATESVILLE ROAD  
P.O. BOX 250  
NORTH WILKESBORO, NORTH CAROLINA 28659

## **INSTRUCTIONS TO BIDDERS**

### **PLEASE READ ALL INSTRUCTIONS CAREFULLY BEFORE PREPARING AND SUBMITTING YOUR BID**

All bids shall be prepared and submitted in accordance with the following requirements. Failure to comply with any requirement shall cause the bid to be considered irregular and shall be grounds for rejection of the bid.

1. The bid sheet furnished by NCDOT with the proposal shall be used and shall not be altered in any manner. **DO NOT SEPARATE THE BID SHEET FROM THE PROPOSAL!**
2. All entries on the bid sheet, including signatures, shall be written in ink.
3. The Bidder shall submit a unit price for every item on the bid form. The unit prices for the various contract items shall be written in figures.
4. An amount bid shall be entered on the bid sheet for every item. The amount bid for each item shall be determined by multiplying each unit bid by the quantity for that item, and shall be written in figures in the "Amount Bid" column of the sheet.
5. The total amount bid shall be written in figures in the proper place on the bid sheet. The total amount shall be determined by adding the amounts bid for each item.
6. Changes in any entry shall be made by marking through the entry in ink and making the correct entry adjacent thereto in ink. A representative of the Bidder shall initial the change in ink.
7. The bid shall be properly executed. All bids shall show the following information:
  - a. Name of individual, firm, corporation, partnership, or joint venture submitting bid.
  - b. Name and signature of individual or representative submitting bid and position or title.
  - c. Name, signature, and position or title of witness.
  - d. Contractor's License Number (if Applicable)
8. Bids submitted by corporations shall bear the seal of the corporation.
9. The bid shall not contain any unauthorized additions, deletions, or conditional bids.
10. The bidder shall not add any provision reserving the right to accept or reject an award, or to enter into a contract pursuant to an award.
11. **THE PROPOSAL WITH THE BID SHEET STILL ATTACHED SHALL BE PLACED IN A SEALED ENVELOPE AND SHALL HAVE BEEN DELIVERED TO AND RECEIVED IN THE DIVISION ENGINEER'S OFFICE AT 801 STATEVILLE ROAD, P.O. BOX 250, NORTH WILKESBORO, NORTH CAROLINA 28659 BY 10:00 AM ON JANUARY 17, 2013.**
12. The sealed bid must display the following statement on the front of the sealed envelope:

**QUOTE NO: 11-02-514 – WATAUGA COUNTY LONG-ARM MOWING**

13. If delivered by mail, the sealed envelope shall be placed in another sealed envelope and the outer envelope shall be addressed as follows:

**JOE L. LAWS, PE, DIVISION PROJECT MANAGER  
N.C. DEPARTMENT OF TRANSPORTATION  
P.O. BOX 250  
801 STATESVILLE ROAD  
NORTH WILKESBORO, NORTH CAROLINA 28659**

### **AWARD OF CONTRACT**

**The award of the contract, if it be awarded, will be made to the lowest responsible Bidder in accordance with Section 102 of the 2012 Standard Specifications for Roads and Structures. The lowest responsible Bidder will be notified that his bid has been accepted and that he has been awarded the contract. NCDOT reserves the right to reject all bids.**

# CONTENTS

|  |           |
|--|-----------|
| <b>General Provisions .....</b>                                    | <b>5</b>  |
| GENERAL .....  | 5         |
| MANDATORY PRE-BID CONFERENCE AND PROPOSAL REVIEW .....             | 5         |
| CONTRACT TIME AND LIQUIDATED DAMAGES .....                         | 7         |
| TERM OF THE CONTRACT .....   | 7         |
| AWARD OF CONTRACT .....  | 7         |
| INTERMEDIATE CONTRACT TIME NUMBER ONE AND LIQUIDATED DAMAGES ..... | 8         |
| MAJOR CONTRACT ITEMS .....   | 9         |
| NO SPECIALTY ITEMS .....   | 9         |
| PREPARATION AND SUBMISSION OF BIDS .....                           | 9         |
| BID BOND .....   | 9         |
| EXECUTION OF SIGNATURE SHEETS AND DEBARMENT CERTIFICATION .....    | 9         |
| AWARD LIMITS ON MULTIPLE PROJECTS .....                            | 10        |
| WORKMEN'S COMPENSATION INSURANCE .....                             | 11        |
| LICENSES .....   | 11        |
| SUBLETTING OF CONTRACT .....                                       | 12        |
| DEFAULT OF CONTRACT .....  | 12        |
| PARTIAL PAYMENT .....  | 12        |
| RETAINAGE AND PROMPT PAYMENT .....                                 | 12        |
| MANDATORY SUBCONTRACTOR INFORMATION .....                          | 13        |
| AVAILABILITY OF FUNDS – TERMINATION OF CONTRACTS .....             | 14        |
| LEGAL RELATIONS AND RESPONSIBILITY TO PUBLIC .....                 | 14        |
| BANKRUPTCY .....   | 15        |
| EXTENSION OF CONTRACT TIME .....                                   | 15        |
| CLAIMS FOR ADDITIONAL COMPENSATION OR EXTENSION OF TIME .....      | 15        |
| CONTRACTOR CLAIM SUBMITTAL FORM .....                              | 15        |
| PROSECUTION AND PROGRESS .....                                     | 16        |
| TEMPORARY SUSPENSION OF WORK .....                                 | 16        |
| AUTHORITY OF THE ENGINEER .....                                    | 16        |
| APPROVAL OF PERSONNEL .....  | 17        |
| SUPERVISION BY CONTRACTOR .....                                    | 17        |
| CONTRACTOR PERSONNEL .....   | 18        |
| INSPECTION .....   | 18        |
| COOPERATION BETWEEN CONTRACTORS .....                              | 18        |
| OUTSOURCING OUTSIDE THE USA .....                                  | 18        |
| PLAN, DETAIL AND QUANTITY ADJUSTMENTS .....                        | 18        |
| UTILITY CONFLICTS .....  | 19        |
| <b>Special Provisions .....</b>                                    | <b>20</b> |
| NOTES TO CONTRACTOR .....  | 20        |
| STATE HIGHWAY ADMINISTRATOR TITLE CHANGE .....                     | 20        |
| NOTIFICATION OF OPERATIONS .....                                   | 20        |
| EMPLOYMENT .....   | 20        |
| LONG-ARM MOWING .....  | 21        |
| EQUIPMENT PROVIDED BY THE CONTRACTOR .....                         | 21        |
| ESTIMATED SUMMARY OF QUANTITIES .....                              | 22        |
| MOWING LIMITS .....  | 23        |
| PRECONSTRUCTION CONFERENCE .....                                   | 25        |
| HOURS OF WORK .....  | 25        |
| CONTRACT BID QUANTITIES .....                                      | 25        |

|  |    |
|--|----|
| DRIVEWAYS AND PRIVATE PROPERTY .....                     | 25 |
| MOBILIZATION .....                                       | 25 |
| TRAFFIC CONTROL AND WORK ZONE SAFETY .....               | 26 |
| TRAFFIC CONTROL, FULL LANE CLOSURE DIVIDED HIGHWAY ..... | 27 |
| ERRATA.....  | 27 |
| MINIMUM WAGES .....                                      | 29 |
| BID FORM.....  | 30 |
| DEBARMENT CERTIFICATION .....                            | 37 |

# DIVISION CONTRACT

## General Provisions

### GENERAL

#### This is a Small Business Enterprise Project.

This contract is for long-arm mowing on various routes upon request in Watauga County under the provisions of North Carolina Department of Transportation's Small Business Enterprise Program. Your firm does not have to be formally identified as a minority, woman, or disadvantaged business to qualify for this program, but your business must have had an annual income of \$1,500,000 or less for the previous calendar year (not including costs for materials). Under the provisions of this Program, contract payment and contract performance bonds are not required.

You must be registered as a Small Business Enterprise through the North Carolina Department of Transportation Contractual Services Unit to be eligible to bid on any SBE project. For more information on becoming registered with the Department, please contact the Office of Contractual Services at (919) 733-5616.

Please be advised that Item Unit Prices will be used to determine the lowest acceptable bidder. Actual Item Quantities will vary and will be determined based upon the amount of erosion control measures required.

All work and materials shall be in accordance with the provisions of the General Guidelines of this contract, the Project Special Provisions, the *North Carolina Department of Transportation Standard Specifications for Roads and Structures*, the *North Carolina Department of Transportation Roadway Standards Drawings*, and the current edition of the *Manual of Uniform Traffic Control Devices (MUTCD)*. These manuals may be found on the internet at:

<http://www.ncdot.gov/doh/preconstruct/ps/specifications/2012draft.pdf>

[http://www.ncdot.gov/doh/preconstruct/ps/std\\_draw/default.html](http://www.ncdot.gov/doh/preconstruct/ps/std_draw/default.html)

<http://mutcd.fhwa.dot.gov/>

### MANDATORY PRE-BID CONFERENCE AND PROPOSAL REVIEW

In order for all prospective bidders to have an extensive knowledge of the project, all prospective bidders shall attend a mandatory pre-bid conference as shown below:

**Date and Time: January 3, 2013 at 10:00 AM**

**Place: Watauga County Maintenance Engineer's Office**

**Location: 1829 Highway 194 North, Jefferson Highway, Boone, NC 28607**

**Contact for Directions: Boone District Engineer's Office – 828-265-5380**

**Note: If you plan to attend this showing, please notify Ken Lisk at 828-265-5380 so that contract materials will be available.**

The Mandatory Pre-Bid Conference will begin promptly at **10:00 AM**. An official clock for the pre-bid conference will be designated. Contractors who are late will not be permitted to sign in or to participate in the conference.

Bidders are expected to make their own investigation of the site prior to the conference.

No questions concerning the project will be answered by any Department personnel at any time, except at the Mandatory Pre-Bid Conference.

This conference will be conducted by Department personnel to ensure all prospective bidders are given an opportunity to obtain information relevant to the project and given an opportunity to ask any questions they may have.

The Engineer will explain areas of responsibility, standards of performance and expected results. This is also intended to be a time for the Contractor to raise questions as to the present condition of the facility. The Contractor is encouraged to make his/her own observations of the sites to determine the condition of the items identified in this contract as the Contractor's responsibility. Any changes made to the contract during the pre-bid conference will be documented and included in an addendum. The entire addendum must be returned with the bid package, signed and dated. Failure to do so will result in disqualification of bid.

### **Eligibility to Bid**

All prospective bidders at the Mandatory Pre-Bid Conference shall meet all of the requirements as shown below:

1. Only Bidders who have attended the entire conference and properly registered at the Mandatory Pre-Bid Conference will be considered eligible to bid on this project. A bid received from a Bidder who has not attended and properly registered at the conference will be rejected as an irregular bid and will not be considered for award.
2. Attendance at the Mandatory Pre-Bid Conference will not meet the requirements of proper registration unless the individual attending has registered at the conference in accordance with the following:
  - The individual attending the Mandatory Pre-Bid Conference is a full time employee of the company being represented and has **administrative and/or supervisory** authority over the work to be performed under this contract.
  - The individual signs his/her name and company title on the official roster.
  - The individual writes in the name and address of the company he or she represents.
  - Only one company is shown as being represented by the individual attending.
  - The individual shall sign out when the conference is over.

**Attendance at any prior pre-bid conference will not meet the requirement of this provision.**

## CONTRACT TIME AND LIQUIDATED DAMAGES

**This contract shall be effective February 1, 2013. Work requests will be made on an as-needed basis; therefore each request will have its own date of availability and required completion date.**

All work will be done at the request of the Engineer. Notification will be made via fax or internet and will include the location of the work, description of the work to be performed, and the approximate quantities required. Each work request may consist of multiple locations within a general work area. Each notification will be considered a separate and independent project.

An intermediate contract time of **fourteen (14) calendar days** from notification will apply to each work request for **Long-Arm Mowing**. In the event that the Contractor fails to respond to location(s) requested by the Engineer within **fourteen (14) calendar days**, liquidated damages in the amount of **Two Hundred Dollars (\$200.00) per working day, or a portion thereof, per work request**, will be deducted from the monies due to the Contractor. No extensions will be authorized except as authorized by Article 108-10 of the *2012 Standard Specifications*.

No work will be permitted and no contract will be executed until all prerequisite conditions and certifications have been satisfied.

## TERM OF THE CONTRACT

The contractor shall submit his bid for one year. At the option of the Department, this contract may be extended two (2) additional periods of one (1) year each (maximum of three (3) years total). The unit bid price will be increased by **three (3) percent** for each one-year extension. No changes in the terms, conditions, etc. of this contract will be made when an extension of the contract is implemented. The Engineer will notify the Contractor in writing by **December 1, 2013** if the contract may be extended. The Contractor must notify the Engineer in writing by **December 15, 2013** of his acceptance or rejection of this offer. Failure on the part of the Contractor to reply will be received as a rejection of contract extension.

**The period covered by this contract will be from February 1, 2013 until January 31, 2014.**

## AWARD OF CONTRACT

The Department reserves the right to make partial, progressive or **multiple awards** for the same service and in the best interest of the state.

The award of the contract **if** it is awarded will be made to the lowest responsible bidder(s). The lowest responsible bidder(s) will be notified that his/her bid has been accepted and that the contract has been awarded. NCDOT reserves the right to reject all bids.

## **INTERMEDIATE CONTRACT TIME NUMBER ONE AND LIQUIDATED DAMAGES**

The Contractor shall not close or narrow a lane of traffic on **any routes**, detain and/or alter the traffic flow on or during holidays, holiday weekends, special events, or any other time when traffic is unusually heavy, including the following schedules:

### **HOLIDAY AND HOLIDAY WEEKEND LANE CLOSURE RESTRICTIONS**

1. For **unexpected occurrence** that creates unusually high traffic volumes, as directed by the Engineer.
2. For **New Year's Day**, between the hours of **3:00 P.M.** December 31st and **9:00 A.M.** January 2nd. If New Year's Day is on a Friday, Saturday, Sunday or Monday, then until **9:00 A.M.** the following Tuesday.
3. For **Martin Luther King Jr Day**, between the hours of **3:00 P.M.** Friday and **9:00 A.M.** Tuesday.
4. For **Easter**, between the hours of **3:00 P.M.** Thursday and **9:00 A.M.** Monday.
5. For **Memorial Day**, between the hours of **3:00 P.M.** Friday and **9:00 A.M.** Tuesday.
6. For **Independence Day**, between the hours of **3:00 P.M.** the day before Independence Day and **9:00 A.M.** the day after Independence Day.

If **Independence Day** is on a Friday, Saturday, Sunday or Monday, then between the hours of **3:00 P.M.** the Thursday before Independence Day and **9:00 A.M.** the Tuesday after Independence Day.

7. For **Labor Day**, between the hours of **3:00 P.M.** Friday and **9:00 A.M.** Tuesday.
8. For **Veteran's Day**, between the hours of **3:00 P.M.** the day before and **9:00 A.M.** the day after.
9. For **Thanksgiving Day**, between the hours of **3:00 P.M.** Tuesday and **9:00 A.M.** Monday.
10. For **Christmas**, between the hours of **3:00 P.M.** the Friday before the week of Christmas Day and **9:00 A.M.** the following Tuesday after the week of Christmas Day.

Holidays and holiday weekends shall include New Year's, Martin Luther King Jr. Day, Easter, Memorial Day, Independence Day, Labor Day, Veteran's Day, Thanksgiving, and Christmas. The Contractor shall schedule his work so that lane closures are not required during these periods, unless otherwise directed by the Engineer.

The time of availability for this intermediate contract work shall be the time the Contractor begins to install all traffic control devices for lane closures according to the time restrictions listed herein.



**The Contractor's operations are restricted to daylight hours. No work may be performed on Saturdays, Sundays and Official State Holidays without approval by the Engineer.**

The completion time for this intermediate contract work shall be the time the Contractor is required to complete the removal of all traffic control devices for lane closures according to the time restrictions stated herein and place traffic in the original traffic pattern. Failure to comply with any of the requirements for safety and traffic control of this contract shall result in suspension of work as provided in Subarticle 108-7(B) of the *2012 Standard Specifications*.

**The liquidated damages are Five Hundred Dollars (\$500.00) per hour.**

### **MAJOR CONTRACT ITEMS**

None of the items included in this contract will be major items.

### **NO SPECIALTY ITEMS**

None of the items included in this contract will be specialty items (see Article 108-6 of the *2012 Standard Specifications*).

### **PREPARATION AND SUBMISSION OF BIDS**

The entire bid proposal package, properly signed and executed, must be returned in order for the bid to be considered as responsive. **Incomplete proposal packages may be considered unresponsive.** Bid proposals shall be completed in ink and any corrections shall have one strike through with the correction initialed by the bidder.

All bids shall be prepared and submitted in accordance with the listed requirements of Article 102-8 of the *2012 Standard Specifications*.

In accordance with GS 136-28.10, if the total bid amount of the contract exceeds **\$500,000**, the bid will not be considered for award.

### **BID BOND**

**No bid bond will be required for the submission of bids for this project.**

### **EXECUTION OF SIGNATURE SHEETS AND DEBARMENT CERTIFICATION**

The Bidder's attention is directed to the various sheets in the contract proposal, which are to be completed and/or signed by the Bidder. A list of these sheets is shown below. The signature sheets are located behind the Bid Form(s) in the contract proposal.

1. Execution of Bid including Non-Collusion Affidavit, Debarment Certification, & Gift Ban
2. MBE/WBE/DBE Subcontract Listing Form

The Bidder shall certify his and to the best of his knowledge all subcontractors, material suppliers and vendors utilized herein current status concerning suspension, debarment, voluntary exclusion, or determination of ineligibility by any federal agency, in accordance with the "Debarment Certification" located behind the signature sheets in the proposal forms. Execution of the bid signature sheets in conjunction with any applicable statements concerning exceptions, when such statements have been made on the "Debarment Certification", constitutes the Bidders certification of "status" under penalty of perjury under the laws of the United States.

**AWARD LIMITS ON MULTIPLE PROJECTS**

It is the desire of the Proposer to be awarded contracts, the value of which will not exceed a total of \$ \_\_\_\_\_, for those projects indicated below on which bids are being opened on the same date as shown in the Proposal Form. Individual projects shall be indicated by placing the project number and county in the appropriate place below. Projects not selected will not be subject to an award limit.

|                  |          |
|------------------|----------|
| (Project Number) | (County) |
| (Project Number) | (County) |
| (Project Number) | (County) |

\*If a Proposer desires to limit the total amount of work awarded to him in this letting, he shall state such limit in the space provided above in the second line of this form.

It is agreed that in the event that I am (we are) the successful bidder on indicated projects, the total value of which is more that the above stipulated award limits, the Board of Transportation will award me (us) projects from among those indicated which have a total value not exceeding the award limit and which will result in the best advantage to the Department of Transportation.

\_\_\_\_\_  
\*\*Signature of Authorized Person

\*\*Only those persons authorized to sign bids under the provisions of Article 102-8, Item 7, shall be authorized to sign this form.

## **WORKMEN'S COMPENSATION INSURANCE**

The contractor shall defend, indemnify and hold harmless the North Carolina Department of Transportation, its officers and employees from any claim, demand, suit, liability, judgment and expense (including attorney's fees and other costs of litigation) arising out of or relating to injury, disease, or death of persons or damage to or loss of property resulting from or in connection with the negligent performance of this contract by the contractor, its agents, employees, and subcontractors or any one for whom the contractor may be responsible. The obligations, indemnities and liabilities assumed by the contractor under this paragraph shall not extend to any liability caused by the negligence of the Department of Transportation or its employees. The contractor's liability shall not be limited by any provisions or limits of insurance set forth in this contract.

The contractor shall indemnify and hold harmless the Department of Transportation from any claim, demand, suit, liability, judgment, and expense involving damage or loss to the contractor's equipment (including vandalism, theft, fire and acts of God) arising out of or relating to work performed under this agreement. The obligations, indemnities and liabilities assumed by the contractor under this paragraph shall not extend to any liability caused by the negligence of the Department of Transportation or its employees. The contractor's liability shall not be limited by any provisions or limits of insurance set forth in this contract.

The contractor further agrees to indemnify the Department of Transportation for any damages to the roadway, highway signs, highway equipment and other property owned or in possession of the Department of Transportation, brought about by reason of the negligent operation of the leased equipment. The contractor further agrees to indemnify and save harmless the Department of Transportation, its officers and employees from any claims or amounts recovered by any of the contractor's employees under the Worker's Compensation Act.

*Pursuant to N.C.G.S. § 97-19, all contractors of the Department of Transportation are, prior to beginning services, required to show proof of coverage issued by a workers' compensation insurance carrier, or a certificate of compliance issued by the Department of Insurance for self-insured subcontractors stating that it has complied with N.C.G.S. § 97-93 irrespective of whether subcontractors have regularly in service fewer than three employees in the same business within the State of North Carolina, and subcontractors shall be hereinafter liable under the Workers' Compensation Act for payment of compensation and other benefits to its employees for any injury or death due to an accident arising out of and in the course of performance of the work insured by the subcontractor.*

**Proof of insurance shall be furnished to the Engineer prior to beginning work.**

## **LICENSES**

Under the provisions of the North Carolina Department of Transportation's Small Business Enterprise Program, the contractor is **not required to possess a contractor's license** to perform work on this contract.

## **SUBLETTING OF CONTRACT**

The Contractor shall not sublet, sell, transfer, assign or otherwise dispose of this contract or any portion thereof; or his right, title, or interest therein; without written consent of the Engineer. Subletting of this contract or any portion of the contract shall conform to the requirements of Article of 108-6 of the *2012 Standard Specifications*.

## **DEFAULT OF CONTRACT**

The Department of Transportation shall have the right to declare a default of contract for breach by the Contractor of any material term or condition of the contract. Default of contract shall be in accordance with the terms, conditions, and procedures of Article 108-9 of the *2012 Standard Specifications*.

## **PARTIAL PAYMENT**

The Contractor may submit a request for payment at the end of each work request. Compensation for all pay items shall be in accordance with the *Standard Specifications*. One hundred percent (100%) payment shall be made after successful completion of the work as verified by the final inspection.

Requests for payment can be made on the form furnished to the Contractor by the Department of Transportation. The form shall be completely and legibly filled out with all appropriate information supplied and shall be signed by an authorized representative of the Contractor.

All invoice items and unit costs shall correspond to contract pay items. In the event of error or discrepancy in items or unit costs, the Department may return the invoice to the contractor for correction. Invoices must be "electronically scanned" by our office and the image is transmitted to the Purchasing Unit to verify payment. To avoid confusion and delay of payments each invoice should have a **Unique Invoice Number**, i.e. 1, 2, 3... In addition, the invoice should be positively identified and associated with the Purchase Order by including the **Purchase Order Number** on the Invoice.

Minority Business Enterprise (MBE), Women's Business Enterprise (WBE) and/or Disadvantage Business Enterprise (DBE) participation shall be listed on the appropriate form (DBE-IS) and shall accompany all requests for payment. If there is no participation the word "**None**" or the figure "**0**" shall be entered. Requests for payment will not be processed without the submission of the DBE-IS form. One hundred percent (100%) payment shall be made after successful completion of the work as verified by the final inspection.

## **RETAINAGE AND PROMPT PAYMENT**

Prompt Payment of Monies Due Subcontractors, Second Tier Subcontractors and Material Suppliers and Release of Retainage

Contractors at all levels; prime, subcontractor, or second tier contractor, shall within seven calendar days of receipt of monies, resulting from work performed on the project or services rendered, pay subcontractors, second tier subcontractors, or material suppliers, as appropriate. This seven-day period begins upon knowledgeable receipt by the contracting firm obligated to make a subsequent periodic or final payment. These prompt payment requirements will be met if each firm mails the payment to the next level firm by evidence of postmark within the seven-day period.

This provision for prompt payment shall be incorporated into each subcontract or second tier subcontract issued for work performed on the project or for services provided.

The Contractor may withhold up to 3% retainage if any subcontractor does not obtain a payment and performance bond for their portion of the work. If any retainage is held on subcontractors, all retainage shall be released within seven calendar days of satisfactory completion of all work. For the purpose of release of retainage, satisfactory completion is defined as completion of all physical elements and corresponding documentation as defined in the contract, as well as agreement between the parties as to the final quantities for all work performed in the subcontract. The Department will provide internal controls to expedite the determination and processing of the final quantities for the satisfactorily completed subcontract portions of the project.

Failure of any entity to make prompt payment as defined herein may result in (1) withholding of money due to that entity in the next partial payment until such assurances are made satisfactory to this provision; or (2) removal of an approved contractor from the prequalified bidders list or the removal of other entities from the approved subcontractors list.

### **MANDATORY SUBCONTRACTOR INFORMATION**

The Contractor is to provide a list of all proposed subcontractors he or she plans to use on this project. This list shall include all subcontractors that will be used, not only MBE, WBE or DBE firms. Only pre-approved subcontractors that are registered with the NCDOT may be used. A listing of all contractors (prime or subcontractor) may be found at the following website:  
<https://partner.ncdot.gov/VendorDirectory/default.html>

Subcontract Approval Form (Form SAF) must be completed for each subcontractor that will be used and returned prior to the issuance of the purchase order. This form can be found at the following website:  
[http://www.ncdot.org/doh/operations/dp\\_chief\\_eng/constructionunit/saf.xls](http://www.ncdot.org/doh/operations/dp_chief_eng/constructionunit/saf.xls)

If the proposed subcontractor cannot fulfill their obligation and a substitute must be used, then an appropriate form for the replacement subcontractor must be delivered to the administering officer before the new subcontractor is used.

**Failure to provide this information (regardless of any goals in contract) may result in the contract being awarded to another contractor.**

## **AVAILABILITY OF FUNDS – TERMINATION OF CONTRACTS**

*General Statute 143C-6-11. (h) Highway Appropriation* is hereby incorporated verbatim in this contract as follows:

(h) Amounts Encumbered. – Transportation project appropriations may be encumbered in the amount of allotments made to the Department of Transportation by the Director for the estimated payments for transportation project contract work to be performed in the appropriation fiscal year. The allotments shall be multiyear allotments and shall be based on estimated revenues and shall be subject to the maximum contract authority contained in *General Statute 143C-6-11(c)*. Payment for transportation project work performed pursuant to contract in any fiscal year other than the current fiscal year is subject to appropriations by the General Assembly. Transportation project contracts shall contain a schedule of estimated completion progress, and any acceleration of this progress shall be subject to the approval of the Department of Transportation provided funds are available. The State reserves the right to terminate or suspend any transportation project contract, and any transportation project contract shall be so terminated or suspended if funds will not be available for payment of the work to be performed during that fiscal year pursuant to the contract. In the event of termination of any contract, the contractor shall be given a written notice of termination at least 60 days before completion of scheduled work for which funds are available. In the event of termination, the contractor shall be paid for the work already performed in accordance with the contract specifications.

Payment will be made on any contract terminated pursuant to the special provision in accordance with Article 108-13(E), of the *North Carolina Department of Transportation Standard Specifications for Roads and Structures, dated January 2012*.

## **LEGAL RELATIONS AND RESPONSIBILITY TO PUBLIC**

### **Laws to be Observed**

In accordance with 107-1 of the *Standard Specifications*, The Contractor shall keep himself fully informed of all Federal and State laws, all local laws, ordinances, and regulations, and all orders and decrees of bodies or tribunals having any jurisdiction or authority which may in any manner affect those engaged or employed in the work, or which in any way affect the conduct of the work. He shall at all times observe and comply with all such laws, ordinances, regulations, orders, and decrees; and shall indemnify and hold harmless the Board of Transportation and the Department of Transportation and their agents and employees from any claim or liability arising from or based on the violation of any such law, ordinance, regulations, order, or decree, by the Contractor or by his agents and employees.

### **Responsibility For Damage Claims**

In accordance with 107-14 of the *Standard Specifications*, The Contractor shall indemnify and save harmless the Board of Transportation and its members and the Department of Transportation and its officers, agents, and employees from all suits, actions, or claims of any character brought for any injury or damages received or sustained by any person, persons, or property by reason of

any act of the Contractor, Subcontractor, its agents or employees, in the performance of the contract.

### **Safety and Accident Protection**

In accordance with 107-21 of the *Standard Specifications*, The Contractor shall comply with all applicable Federal, State, and local laws, ordinances, and regulations governing safety, health, and sanitation, and shall provide all safeguards, safety devices, and protective equipment, and shall take any other needed actions, on his own responsibility that are reasonably necessary to protect the life and health of employees on the job and the safety of the public, and to protect property in connection with the performance of the work covered by the contract.

### **BANKRUPTCY**

The Department of Transportation, at its option, may terminate the contract upon the filing by the contractor of any petition for protection under the provisions of the Federal Bankruptcy Act.

### **EXTENSION OF CONTRACT TIME**

Failure on the part of the Contractor to furnish bonds or certifications or to satisfy preliminary requirements necessary to issue the purchase order will not constitute grounds for extension of the contract time. If the Contractor has fulfilled all preliminary requirements for the issuance of a purchase order, and the purchase order authorization is not available by the date of availability, the Contractor shall be granted an extension equal to the number of calendar days the purchase order authorization is delayed after the date of availability.

### **CLAIMS FOR ADDITIONAL COMPENSATION OR EXTENSION OF TIME**

Any claims for additional compensation and/or extensions of the completion date shall be submitted to the Division Engineer with detailed justification within thirty (30) days after receipt of the final invoice payment. The failure of the Contractor to submit the claim(s) within thirty days shall be a bar to recovery.

### **CONTRACTOR CLAIM SUBMITTAL FORM**

If the Contractor elects to file a written claim or requests an extension of contract time, it shall be submitted on the Contractor Claim Submittal Form (CCSF) available through the Construction Unit or [http://ncdot.org/doh/operations/dp\\_chief\\_eng/constructionunit/formsmanuals/](http://ncdot.org/doh/operations/dp_chief_eng/constructionunit/formsmanuals/).

## **PROSECUTION AND PROGRESS**

The Contractor will be required to prosecute the work in a continuous and uninterrupted manner from the time he begins the work until completion and final acceptance of the project. The contractor will not be permitted to suspend his operations except for reasons beyond his control except where the Engineer has authorized a suspension of the contractor's operations in writing.

The Contractor shall pursue the work diligently with workmen in sufficient numbers, abilities, and supervision, and with equipment, materials, and methods of construction as may be required to complete the work described in the contract by the completion date and in accordance with Section 108 of the *Standard Specifications*.

## **TEMPORARY SUSPENSION OF WORK**

In accordance with Article 108-7 of the *2012 Standard Specifications*, the Engineer will have the authority to suspend the work wholly or in part, any written order for such periods as he may deem necessary for any of the following reasons.

1. Conditions considered unfavorable for the suitable prosecution of the work, or
2. The Contractor's failure for correct conditions unsafe for workmen or the general public, or
3. The Contractor has not carried out orders given to him by the Engineer, or
4. The Contractor's failure to perform any provisions of the contract.

No extension of the completion date will be allowed for the above suspensions except as may be provided for in Article 108-10.

## **AUTHORITY OF THE ENGINEER**

The Engineer for this project shall be the Division Engineer, Division 11, Division of Highways, North Carolina Department of Transportation, acting directly or through his duly authorized representatives.

The Engineer will decide all questions which may arise as to the quality and acceptability of work performed and as to the rate of progress of the work; all questions which may arise as to the interpretation of the contract; and all questions as to the acceptable fulfillment of the contract on the part of the Contractor. His decision shall be final, and he shall have executive authority to enforce and make effective such decisions and orders as the Contractor fails to carry out promptly.



## **APPROVAL OF PERSONNEL**

The State shall have the right to approve or reject the project engineer and other supervisory personnel, assigned to a project.

The Engineers or any subcontractor for the Engineers which are employed to provide engineering services for this project shall not engage the services of any person or persons, now in the employment of the State during the time of this Agreement, without written consent of the State.

In the event of engagement, the Engineers or their subcontractors shall restrict such person or persons from working on any of the Engineers' contracted projects in which the person or persons were formerly involved while employed by the State. This restriction period shall be for the duration of the contracted project with which the person or persons was involved. "Involvement" shall be defined as active participation in any of the following activities:

- Drafting the contract;
- Defining the scope of the contract;
- Selection of the Engineers' firm for services;
- Negotiation of the cost of the contract (including calculating man-hours or fees); and
- Administration of the contract.

An exception to these terms may be granted when recommended by the Secretary and approved by the Board of Transportation. Failure to comply with the terms stated above in this section shall be grounds for termination of this contract.

## **SUPERVISION BY CONTRACTOR**

At all times during the life of the project the Contractor shall provide one permanent employee who shall have the authority and capability for overall responsibility of the project and who shall be personally available at the work site within 24 hours notice. Such employee shall be fully authorized to conduct all business with the subcontractors, to negotiate and execute all supplemental agreements, and to execute the orders or directions of the Engineer.

At all times that work is actually being performed, the Contractor shall have present on the project one competent individual who is authorized to act in a supervisory capacity over all work on the project, including work subcontracted. The individual who has been so authorized shall be experienced in the type of work being performed and shall be fully capable of managing, directing, and coordinating the work; of reading and thoroughly understanding the contract; and receiving and carrying out directions from the Engineer or his authorized representatives. He shall be an employee of the Contractor unless otherwise approved by the Engineer.

The Contractor may, at his option, designate one employee to meet the requirements of both positions. However, whenever the designated employee is absent from the work site, an authorized individual qualified to act in a supervisory capacity on the project shall be present.

## **CONTRACTOR PERSONNEL**

The Department will not be responsible in any way to the Contractor's personnel for damages, destruction or loss, from any cause, to the Contractor's equipment, supplies, materials or tools or the personal property of the Contractor's personnel. The Contractor will be responsible for all repairs, regardless of cost, resulting from the negligence of the Contractor or Contractor's employees. The Department will not participate in the cost of such repairs.

## **INSPECTION**

All work shall be subject to inspection by the Engineer at any time. Routinely, the Engineer will make periodic inspections of the completed work. It will be the responsibility of the Contractor to keep the Engineer informed of his proposed work plan and to submit written reports of work accomplished on a frequency to be determined by the Engineer.

## **COOPERATION BETWEEN CONTRACTORS**

The Contractor's attention is directed to Article 105-7 of the *2012 Standard Specifications*.

The Contractor on this project shall cooperate with Contractor(s) and state forces working within or adjacent to the limits of this project to the extent that the work can be carried out to the best advantage of all concerned.

## **OUTSOURCING OUTSIDE THE USA**

All work on consultant contracts, services contracts, and construction contracts shall be performed in the United States of America. No work shall be outsourced outside of the United States of America.

*Outsourcing* for the purpose of this provision is defined as the practice of subcontracting labor, work, services, staffing, or personnel to entities located outside of the United States.

The North Carolina Secretary of Transportation shall approve exceptions to this provision in writing.

## **PLAN, DETAIL AND QUANTITY ADJUSTMENTS**

The Department reserves the right to make, at any time during the progress of the work, such alterations in plans or the details of construction as may be found necessary or desirable by the Engineer to complete the project.

## **UTILITY CONFLICTS**

**It shall be the responsibility of the Contractor to contact all affected utility owners and determine the precise locations of all utilities prior to beginning construction. Utility owners shall be contacted a minimum of 48 hours prior to the commencement of operations. Special care shall be used in working around or near existing utilities, protecting them when necessary to provide uninterrupted service. In the event that any utility service is interrupted, the Contractor shall notify the utility owner immediately and shall cooperate with the owner, or his representative, in the restoration of service in the shortest time possible. Existing fire hydrants shall be kept accessible to fire departments at all times.**

The Contractor shall adhere to all applicable regulations and follow accepted safety procedures when working in the vicinity of utilities in order to insure the safety of construction personnel and the public.

## **GIFTS FROM VENDORS AND CONTRACTORS**

By Executive Order 24, issued by Governor Perdue, and *N.C. G.S. § 133-32*, it is unlawful for any vendor or contractor (i.e. architect, bidder, contractor, construction manager, design professional, engineer, landlord, offer or, seller, subcontractor, supplier, or vendor), to make gifts or to give favors to any State employee of the Governor's Cabinet Agencies (i.e. Administration, Commerce, Correction, Crime Control and Public Safety, Cultural Resources, Environment and Natural Resources, Health and Human Services, Juvenile Justice and Delinquency Prevention, Revenue, Transportation, and the Office of the Governor). This prohibition covers those vendors and contractors who:

- (1) have a contract with a governmental agency; or
- (2) have performed under such a contract within the past year; or
- (3) anticipate bidding on such a contract in the future.

For additional information regarding the specific requirements and exemptions, vendors and contractors are encouraged to review Executive Order 24 and *G.S. § 133-32*.

Executive Order 24 also encouraged and invited other State Agencies to implement the requirements and prohibitions of the Executive Order to their agencies. Vendors and contractors should contact other State Agencies to determine if those agencies have adopted Executive Order 24.

## **Special Provisions**

### **NOTES TO CONTRACTOR**

1. Refer to the *Standard Specifications for Roads and Structures and Roadway Standard Drawings dated January 2012* and any Special Provisions in contract for guidelines on this project.
2. Quantities included in this contract will vary and will be determined by the actual amount of “Long-Arm Mowing” required.
3. A marked county map showing the routes to be mowed will be provided by the County Maintenance Engineer prior to the start of work.
4. Any damage to adjacent shoulders, medians, paved areas or other facilities shall be repaired or replaced by the Contractor to the satisfaction of the Engineer.
5. All work performed by the contractor shall be in compliance with the *2012 Standard Specifications* and Workmanship/Appearance done to the satisfaction of the Engineer.
6. All work items necessary to complete the work other than listed on the "Bid Proposal Form" will be considered incidental in nature and no further compensation will be made. Any work performed in an unsatisfactory manner could be basis for cancellation of the contract.

### **STATE HIGHWAY ADMINISTRATOR TITLE CHANGE**

Revise the *2012 Standard Specifications* as follows:

Replace all references to “State Highway Administrator” with “Chief Engineer”.

### **NOTIFICATION OF OPERATIONS**

The Contractor or their appointed representative shall notify the Engineer one week in advance of beginning work on any site included in this contract. The Contractor shall give the Engineer sufficient notice of all operations for any sampling or acceptance testing required.

### **EMPLOYMENT**

Revise the *2012 Standard Specifications* as follows:

**Page 1-20, Subarticle 102-15(O)**, delete and replace with the following:

(O) Failure to restrict a former Department employee as prohibited by Article 108-5.

**Page 1-65, Article 108-5 Character of Workmen, Methods, and Equipment, line 32**, delete all of line 32, the first sentence of the second paragraph and the first word of the second sentence of the second paragraph.

### **LONG-ARM MOWING**

This is for vegetation trimming using long arm mowers along designated routes within the county. The County Maintenance Engineer will select and coordinate the locations to be mowed and provide a map of mowing routes to the contractor. All work must be accomplished during daylight hours. No night work is permitted. A Truck Mounted Impact Attenuator (TMIA) shall be required for long-arm mowing operations not performed within a flagging operation or lane closure and is incidental to the operation being performed.

All routes shall be mowed to the top of the cut slope, to the bottom of the fill slope, or to the limit of the equipment. Vegetation hanging over the cut slope shall be mown to the limit of the mower. All vegetation **five inches (5’’) in diameter or less** shall be cut. Cut vegetation shall be cleaned up or mulched. All brush or debris which falls into the roadway shall be immediately removed by the Contractor.

### **Measurement and Payment**

Payment will be made under:

| <b>Pay Item</b>                            | <b>Pay Unit</b> |
|--|-----------------|
| Long-Arm Mowing – Primary Routes           | Shoulder Mile   |
| Long-Arm Mowing – Secondary Paved Routes   | Shoulder Mile   |
| Long-Arm Mowing – Secondary Unpaved Routes | Shoulder Mile   |
| Long-Arm Mowing – Divided Highway          | Shoulder Mile   |

### **EQUIPMENT PROVIDED BY THE CONTRACTOR**

**A minimum of one long arm-mowing tractor will be required to be present and operating within any work zone.**

All contour mowers provided under this contract shall be hydraulic powered, and shall reach a minimum of seventeen feet (17 ft) from the center of the steering wheel. Mower hydraulics shall be controlled from within the driver compartment. The tractor shall have sufficient horsepower to operate the mower per mower manufacturer recommendations. The Department will not be responsible for damage to the Contractor’s equipment. Mowers are to be equipped with shields, which preclude foreign objects from being thrown out from the cutting unit enclosures. Tractors shall be equipped so as to conform to the prevailing Occupational Safety Health Act Standards. Tractors shall also be equipped with a minimum of two outside blinking amber lights, visible from

both directions and one top of the cab mounted amber rotating light, visible from both directions. The Contractor must furnish, mount, and maintain a “Caution Mower” sign on the rear of each mower. In addition, the Contractor shall display his company name on each tractor.

The Contractor shall furnish all equipment in good operating condition and operated by properly trained and qualified personnel. There will be **no payment for mobilization** of labor and equipment, as it will be **considered incidental** to the bid items of this contract. The Contractor shall be responsible for all costs or charges incurred in the operation and maintenance of the equipment during the performance of this contract.

**ESTIMATED SUMMARY OF QUANTITIES**

**LONG ARM MOWING ALONG VARIOUS ROUTES IN AVERY COUNTY**

|                                 |                    |
|---------------------------------|--------------------|
| (Primary Routes).....           | 100 SHOULDER MILES |
| (Secondary Paved Routes).....   | 100 SHOULDER MILES |
| (Secondary Unpaved Routes)..... | 100 SHOULDER MILES |
| (Divided Highway).....          | 100 SHOULDER MILES |

The Contractor shall be required to cut and mulch any tree five (5) inches or less in diameter as close to the ground as the mowing will allow.

\*NOTE\* ---- LONG-ARM MOWING WILL BE DETERMINED BY NEED – PRIORITIES WILL BE SET AFTER NEEDS HAVE BEEN DETERMINED – QUANTITIES ARE ESTIMATES AND ARE FOR INFORMATION ONLY.

# MOWING LIMITS

MOWING LIMITS- TOE OF SLOPE

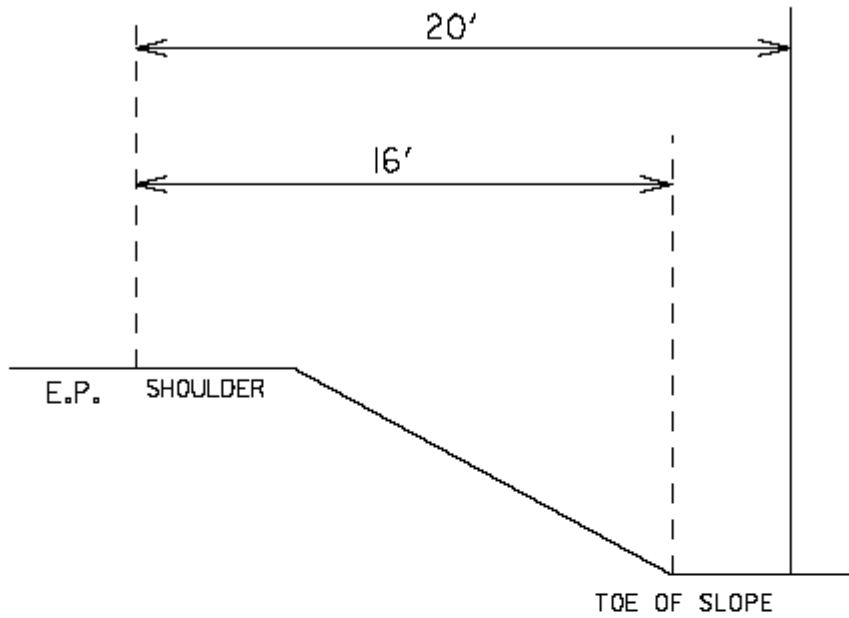

MOWING LIMITS- 20 FEET

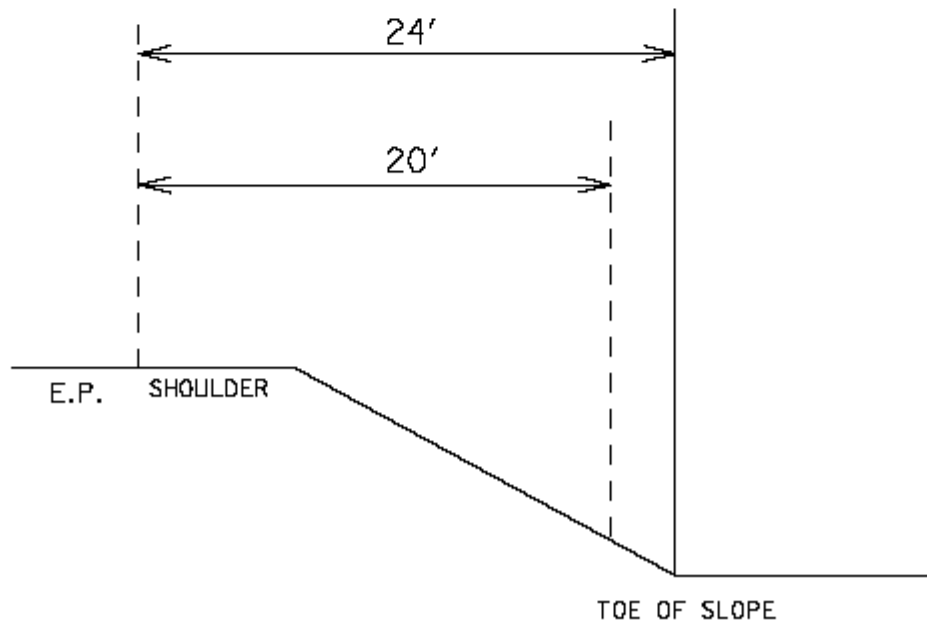

MOWING LIMITS- TOP OF SLOPE

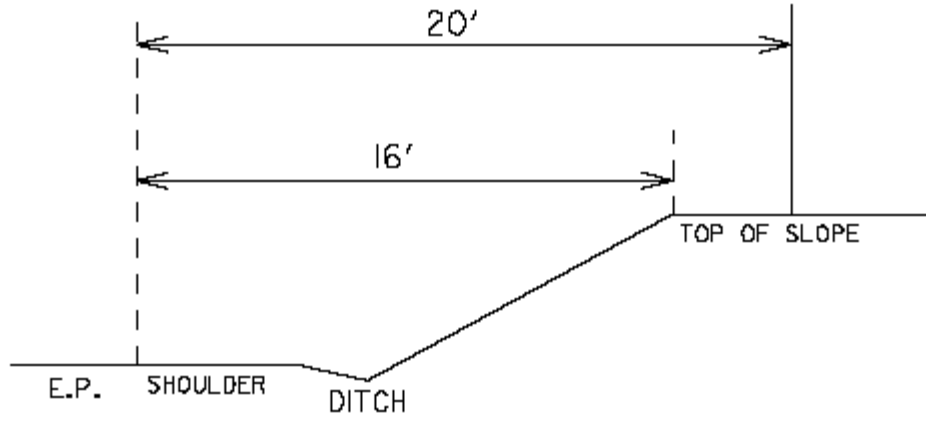

MOWING LIMITS- 20 FEET

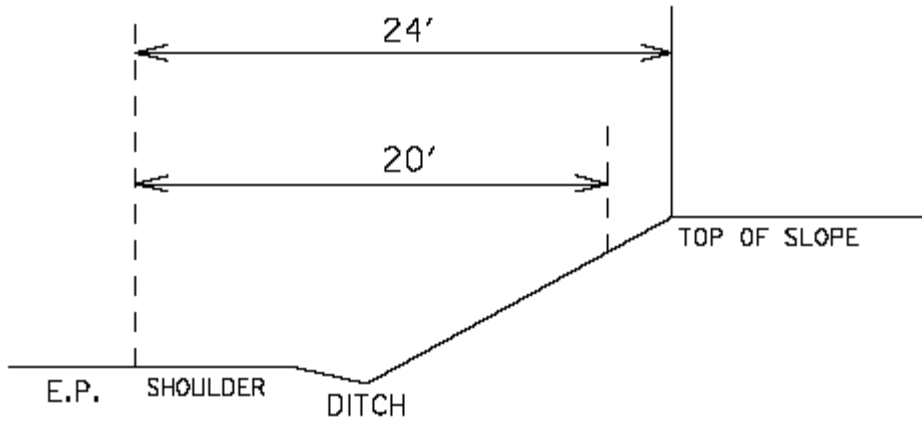



## **PRECONSTRUCTION CONFERENCE**

Following the award of the contract and prior to beginning work, the Contractor shall contact **Kevin Whittington, Watauga County Maintenance Engineer, at 828-265-5378**, to arrange a Pre-construction conference. The project superintendent is required to attend the Pre-construction conference.

## **HOURS OF WORK**

The Contractor's operations are restricted to daylight hours. No work may be performed on Saturdays, Sundays, and Official State Holidays unless **approved by the Engineer**. Work shall only be performed when weather and visibility conditions allow safe operations. The Contractor shall not close any lane or obstruct traffic in any way during the time restrictions shown in Intermediate Contract Time and Liquidated Damages Provision contained on pages 7 and 8 of the Contract Proposal.

## **CONTRACT BID QUANTITIES**

The quantities shown in the itemized proposal for the project are considered to be approximate only and are given as the basis for comparison of bids. The Department of Transportation may increase or decrease the quantity of any item or portion of the work as may be deemed necessary or expedient.

An increase or decrease in the quantity of any item will not be regarded as sufficient ground for an increase or decrease in the unit prices, nor in the time allowed for the completion of the work, except as provided for the contract.

Contractor's pricing shall be based on the estimated quantities per Division. These estimated amounts are submitted to assist contractors in the bidding process. Estimated quantities are not to be regarded as actual requirements. The State shall not be obligated to purchase any specific quantity.

## **DRIVEWAYS AND PRIVATE PROPERTY**

The Contractor shall maintain access to driveways for all residents and property owners throughout the life of the contract. The Contractor shall not perform work for private citizens or agencies in conjunction with this project or within the project limits of this contract.

## **MOBILIZATION**

The contractor will be notified of the required "Long-Arm Mowing" by the Engineer and shall begin work within **fourteen (14) calendar days** after notification or as determined by the

Engineer. Failure to respond within the designated time frame or as approved by the Engineer may result in cancellation of this contract.

**No direct payment will be made for Mobilization as it shall be considered incidental to other bid items in this contract.**

### **TRAFFIC CONTROL AND WORK ZONE SAFETY**

The Contractor shall maintain traffic during construction and shall provide, install, and maintain all traffic control devices in accordance with these project guidelines, the *Project Special Provisions, 2012 North Carolina Department of Transportation Standard Specifications for Roads and Structures, 2012 North Carolina Department of Transportation Roadway Standards Drawings*, and the current edition of the *MUTCD*.

The Contractor's attention is directed to *Section 1101.01 of the 2012 North Carolina Department of Transportation Roadway Standards Drawings*. The Contractor shall utilize complete and proper traffic control and traffic control devices during all operations. All traffic control and traffic control devices required for any operation shall be functional and in place prior to the commencement of that operation. Signs for temporary operations shall be removed during periods of inactivity. The Contractor is required to leave the project in a manner that will be safe to the traveling public and which will not impede motorists.

Traffic movements through lane closures on roads with two-way traffic shall be controlled by flaggers stationed at each end of the work zone. In situations where sight distance is limited, the Contractor shall provide additional means of controlling traffic, including, but not limited to, two-way radios, pilot vehicles, or additional flaggers. Flaggers shall be competent personnel, adequately trained in flagging procedures, and furnished with proper safety devices and equipment, including, but not limited to, safety vests and stop/slow paddles.

All personnel when working in traffic areas or areas in close proximity to traffic shall wear an approved safety vest, or shirt or jacket which meets the color requirements of the *MUTCD*.

The Contractor shall comply with all applicable Federal, State, and local laws, ordinances, and regulations governing safety, health, and sanitation, and shall provide all safeguards, safety devices, and protective equipment, and shall take any other needed actions, on his own responsibility that are reasonably necessary to protect the life and health of employees on the job and the safety of the public, and to protect property in connection with the performance of the work covered by the contract.

Failure to comply with any of the requirements for safety and traffic control of this contract shall result in suspension of work as provided in Subarticle 108-7 of the *Standard Specifications*.

**No direct payment** will be made for the signing and traffic control items including Truck Mounted Impact Attenuators (TMIA - see Section 1165 of the *Standard Specifications* and the *Roadway Standard Drawings*). This work will be considered incidental to the various other bid items in the contract.

**NOTE: Traffic Control Drawing Specifications as found in the 2012 Roadway Standard Drawings are to be used as a guide for reference only and are not to be considered a “best fit” for all traffic control situations. The Contractor is required to discuss any “Lane Closure” plans with the County Maintenance Engineer to insure that particular circumstances are addressed.**

### **TRAFFIC CONTROL, FULL LANE CLOSURE DIVIDED HIGHWAY**

As stated in the General Provisions of this contract, the contractor shall maintain traffic during work on this project. The contractor shall provide and utilize complete and proper traffic controls and traffic control devices during all operations. All traffic control and traffic control devices required for any operation shall be functional and in place prior to the commencement of that operation. All signs, lights, flaggers and other traffic control devices shall be considered incidental to the work of this contract with the exception of a full lane closure on a multilane freeway or expressway.

When Long-Arm Mowing is performed on multilane facilities, such as freeways or expressways, and the Contractor must be in the roadway to perform the work, a full lane closure shall be used. Full lane closures may also be required at the discretion of the Engineer. A full lane closure, for the purposes of this contract, is where conditions warrant the use of a flashing arrow panel, a dual indicating series of signs, merging taper(s), and possibly a truck mounted impact attenuator. In an urban location, where traffic speeds are low, and traffic control can be handled by signs; cones and flaggers shall not be considered a full lane closure.

The contractor, as stated in this contract, shall be responsible for providing all necessary traffic control. This shall include any full lane closure on a multilane facility. Every effort shall be made to minimize the number of lane closures required to perform this work. The Engineer shall decide the appropriate length of any lane closures; however, no single lane closure shall be more than 1.5 miles in length. The contractor shall exercise every effort to perform as much work as possible in a manner that will eliminate the need for any lane closures.

### **Method of Payment**

Payment for the work covered under this provision is incidental and considered full compensation for the pay item “Long-Arm Mowing – Divided Highway”.

### **ERRATA**

Revise the 2012 Standard Specifications as follows:

#### **Division 2**

**Page 2-7, line 31, Article 215-2 Construction Methods,** replace “Article 107-26” with “Article 107-25”.

**Page 2-17, Article 226-3, Measurement and Payment, line 2,** delete “pipe culverts.”.

**Page 2-20, Subarticle 230-4(B), Contractor Furnished Sources, change references as follows: Line 1,** replace “(4) Buffer Zone” with “(c) Buffer Zone”; **Line 12,** replace “(5) Evaluation for Potential Wetlands and Endangered Species” with “(d) Evaluation for Potential Wetlands and Endangered Species”; and **Line 33,** replace “(6) Approval” with “(4) Approval”.

#### **Division 4**

**Page 4-77, line 27, Subarticle 452-3(C) Concrete Coping,** replace “sheet pile” with “reinforcement”.

#### **Division 6**

**Page 6-7, line 31, Article 609-3 Field Verification of Mixture and Job Mix Formula Adjustments,** replace “30” with “45”.

**Page 6-10, line 42, Subarticle 609-6(C)(2),** replace “Subarticle 609-6(E)” with “Subarticle 609-6(D)”.

**Page 6-11, Table 609-1 Control Limits,** replace “Max. Spec. Limit” for the Target Source of  $P_{0.075}/P_{be}$  Ratio with “1.0”.

**Page 6-40, Article 650-2 Materials,** replace “Subarticle 1012-1(F)” with “Subarticle 1012-1(E)”

#### **Division 10**

**Page 10-74, Table 1056-1 Geotextile Requirements,** replace “50%” for the UV Stability (Retained Strength) of Type 5 geotextiles with “70%”.

#### **Division 12**

**Page 12-8, Table 1205-4 and 1205-5,** replace “THERMOPLASTIC” in the title of these tables with “POLYUREA”.

#### **Division 15**

**Page 15-6, Subarticle 1510-3(B), after line 21,** replace the allowable leakage formula with the following:  $W = LD\sqrt{P} + 148,000$

**Page 15-6, Subarticle 1510-3(B), line 32,** delete “may be performed concurrently or” and replace with “shall be performed”.

**Page 15-17, Subarticle 1540-3(E), line 27,** delete “Type 1”.

#### **Division 17**

**Page 17-26, line 42, Subarticle 1731-3(D) Termination and Splicing within Interconnect Center,** delete this subarticle.

Revise the *2012 Roadway Standard Drawings* as follows:

**1633.01 Sheet 1 of 1, English Standard Drawing for Matting Installation,** replace “1633.01” with “1631.01”.

## **MINIMUM WAGES**

**FEDERAL** The Fair Labor Standards Act provides that with certain exceptions every employer shall pay wages at the rate of not less than SEVEN DOLLARS AND TWENTY-FIVE CENTS (\$7.25) per hour.

**STATE** The North Carolina Minimum Wage Act provides that every employer shall pay to each of his employees' wages at a rate of not less than SEVEN DOLLARS AND TWENTY-FIVE CENTS (\$7.25) per hour.

The minimum wage paid to all skilled labor employed on this contract shall be SEVEN DOLLARS AND TWENTY-FIVE CENTS (\$7.25) per hour.

The minimum wage paid to all intermediate labor employed on this contract shall be SEVEN DOLLARS AND TWENTY-FIVE CENTS (\$7.25) per hour.

The minimum wage paid to all unskilled labor on this contract shall be SEVEN DOLLARS AND TWENTY-FIVE CENTS (\$7.25) per hour.

This determination of the intent of the application of this act to the contract on this project is the responsibility of the Contractor.

The Contractor shall have no claim against the Department of Transportation for any changes in the minimum wage laws, State or Federal. It is the responsibility of the Contractor to keep himself fully informed of all Federal and State Laws affecting his contract.

# NORTH CAROLINA DEPARTMENT OF TRANSPORTATION **BID FORM**

WBS Element: To Be Assigned

Contract Number: 11-02-514

DESCRIPTION: Long-Arm Mowing on Various Routes upon request in Watauga County, North Carolina

PAGE 1 OF 1

| ITEM | SECT | DESCRIPTION                               | QUANTITY | UNIT | UNIT PRICE | AMOUNT BID |
|------|------|---|----------|------|------------|------------|
| 1    | SP   | Long-Arm Mowing – Primary Routes          | 100      | SMI  |            |            |
| 2    | SP   | Long-Arm Mowing- Secondary Paved Routes   | 100      | SMI  |            |            |
| 3    | SP   | Long-Arm Mowing- Secondary Unpaved Routes | 100      | SMI  |            |            |
| 4    | SP   | Long-Arm Mowing- Divided Highway          | 100      | SMI  |            |            |

**\*ESTIMATED QUANTITIES ONLY - These quantities are for bid purposes only. Actual quantities may vary greatly from the estimated quantities.**

|                                     |
|-------------------------------------|
| <b>TOTAL BID FOR PROJECT:</b> _____ |
|-------------------------------------|

---

**THIS SECTION TO BE COMPLETED BY NORTH CAROLINA DEPARTMENT OF TRANSPORTATION**

*This bid has been reviewed in accordance with Article 103-1 of the Standard Specifications for Roads and Structures 2012.*

Reviewed by \_\_\_\_\_ (date)

**EXECUTION OF BID**

**NON-COLLUSION AFFIDAVIT, DEBARMENT CERTIFICATION AND GIFT BAN CERTIFICATION**

**CORPORATION**

The person executing the bid, on behalf of the Bidder, being duly sworn, solemnly swears (or affirms) that neither he, nor any official, agent or employee of the bidder has entered into any agreement, participated in any collusion, or otherwise taken any action which is in restraint of free competitive bidding in connection with any bid or contract, that the bidder has not been convicted of violating *N.C.G.S. § 133-24* within the last three years, and that the Bidder intends to do the work with its own bonafide employees or subcontractors and is not bidding for the benefit of another contractor.

In addition, execution of this bid in the proper manner also constitutes the Bidder's certification of status under penalty of perjury under the laws of the United States in accordance with the Debarment Certification attached, provided that the Debarment Certification also includes any required statements concerning exceptions that are applicable.

*N.C.G.S. § 133-32* and Executive Order 24 prohibit the offer to, or acceptance by, any State Employee of any gift from anyone with a contract with the State, or from any person seeking to do business with the State. By execution of any response in this procurement, you attest, for your entire organization and its employees or agents, that you are not aware that any such gift has been offered, accepted, or promised by any employees of your organization.

**SIGNATURE OF CONTRACTOR**

\_\_\_\_\_ Full name of Corporation

\_\_\_\_\_ Address as Prequalified

Attest \_\_\_\_\_  
Secretary/Assistant Secretary  
Select appropriate title

By \_\_\_\_\_  
President/Vice President/Assistant Vice President  
Select appropriate title

\_\_\_\_\_ Print or type Signer's name

\_\_\_\_\_ Print or type Signer's name

**CORPORATE SEAL**

**AFFIDAVIT MUST BE NOTARIZED**

Subscribed and sworn to before me this the  
\_\_\_\_\_ day of \_\_\_\_\_, 20\_\_\_\_.

\_\_\_\_\_ Signature of Notary Public

of \_\_\_\_\_ County.

State of \_\_\_\_\_

My Commission Expires: \_\_\_\_\_

**NOTARY SEAL**

**EXECUTION OF BID**

**NON-COLLUSION AFFIDAVIT, DEBARMENT CERTIFICATION AND GIFT BAN CERTIFICATION**

**PARTNERSHIP**

The person executing the bid, on behalf of the Bidder, being duly sworn, solemnly swears (or affirms) that neither he, nor any official, agent or employee of the bidder has entered into any agreement, participated in any collusion, or otherwise taken any action which is in restraint of free competitive bidding in connection with any bid or contract, that the bidder has not been convicted of violating *N.C.G.S. § 133-24* within the last three years, and that the Bidder intends to do the work with its own bonafide employees or subcontractors and is not bidding for the benefit of another contractor.

In addition, execution of this bid in the proper manner also constitutes the Bidder's certification of status under penalty of perjury under the laws of the United States in accordance with the Debarment Certification attached, provided that the Debarment Certification also includes any required statements concerning exceptions that are applicable.

*N.C.G.S. § 133-32* and Executive Order 24 prohibit the offer to, or acceptance by, any State Employee of any gift from anyone with a contract with the State, or from any person seeking to do business with the State. By execution of any response in this procurement, you attest, for your entire organization and its employees or agents, that you are not aware that any such gift has been offered, accepted, or promised by any employees of your organization.

**SIGNATURE OF CONTRACTOR**

\_\_\_\_\_  
Full Name of Partnership

\_\_\_\_\_  
Address as Prequalified

\_\_\_\_\_  
Signature of Witness

By \_\_\_\_\_  
Signature of Partner

\_\_\_\_\_  
Print or type Signer's name

\_\_\_\_\_  
Print or type Signer's name

**AFFIDAVIT MUST BE NOTARIZED**

Subscribed and sworn to before me this the  
\_\_\_\_ day of \_\_\_\_\_, 20\_\_\_\_.

\_\_\_\_\_  
Signature of Notary Public

**NOTARY SEAL**

of \_\_\_\_\_ County.

State of \_\_\_\_\_

My Commission Expires: \_\_\_\_\_



**EXECUTION OF BID**

**NON-COLLUSION AFFIDAVIT, DEBARMENT CERTIFICATION AND GIFT BAN CERTIFICATION**

**LIMITED LIABILITY COMPANY**

The person executing the bid, on behalf of the Bidder, being duly sworn, solemnly swears (or affirms) that neither he, nor any official, agent or employee of the bidder has entered into any agreement, participated in any collusion, or otherwise taken any action which is in restraint of free competitive bidding in connection with any bid or contract, that the bidder has not been convicted of violating *N.C.G.S. § 133-24* within the last three years, and that the Bidder intends to do the work with its own bonafide employees or subcontractors and is not bidding for the benefit of another contractor.

In addition, execution of this bid in the proper manner also constitutes the Bidder's certification of status under penalty of perjury under the laws of the United States in accordance with the Debarment Certification attached, provided that the Debarment Certification also includes any required statements concerning exceptions that are applicable.

*N.C.G.S. § 133-32* and Executive Order 24 prohibit the offer to, or acceptance by, any State Employee of any gift from anyone with a contract with the State, or from any person seeking to do business with the State. By execution of any response in this procurement, you attest, for your entire organization and its employees or agents, that you are not aware that any such gift has been offered, accepted, or promised by any employees of your organization.

**SIGNATURE OF CONTRACTOR**

\_\_\_\_\_ Full Name of Firm

\_\_\_\_\_ Address as Prequalified

\_\_\_\_\_ Signature of Manager \_\_\_\_\_

Signature of Witness

Individually

\_\_\_\_\_ Print or type Signer's name

\_\_\_\_\_ Print or type Signer's name

**AFFIDAVIT MUST BE NOTARIZED**

Subscribed and sworn to before me this the

\_\_\_\_\_ day of \_\_\_\_\_, 20\_\_\_\_.

\_\_\_\_\_ Signature of Notary Public

**NOTARY SEAL**

of \_\_\_\_\_ County.

State of \_\_\_\_\_

My Commission Expires: \_\_\_\_\_



**EXECUTION OF BID**

**NON-COLLUSION AFFIDAVIT, DEBARMENT CERTIFICATION AND GIFT BAN CERTIFICATION**

**INDIVIDUAL DOING BUSINESS UNDER A FIRM NAME**

The person executing the bid, on behalf of the Bidder, being duly sworn, solemnly swears (or affirms) that neither he, nor any official, agent or employee of the bidder has entered into any agreement, participated in any collusion, or otherwise taken any action which is in restraint of free competitive bidding in connection with any bid or contract, that the bidder has not been convicted of violating *N.C.G.S. § 133-24* within the last three years, and that the Bidder intends to do the work with its own bonafide employees or subcontractors and is not bidding for the benefit of another contractor.

In addition, execution of this bid in the proper manner also constitutes the Bidder's certification of status under penalty of perjury under the laws of the United States in accordance with the Debarment Certification attached, provided that the Debarment Certification also includes any required statements concerning exceptions that are applicable.

*N.C.G.S. § 133-32* and Executive Order 24 prohibit the offer to, or acceptance by, any State Employee of any gift from anyone with a contract with the State, or from any person seeking to do business with the State. By execution of any response in this procurement, you attest, for your entire organization and its employees or agents, that you are not aware that any such gift has been offered, accepted, or promised by any employees of your organization.

**SIGNATURE OF CONTRACTOR**

Name of Contractor

\_\_\_\_\_

Individual Name

Trading and doing business as

\_\_\_\_\_

Full name of Firm

\_\_\_\_\_

Address as Prequalified

\_\_\_\_\_

Signature of Witness

\_\_\_\_\_

Signature of Contractor, Individually

\_\_\_\_\_

Print or type Signer's name

\_\_\_\_\_

Print or type Signer's name

**AFFIDAVIT MUST BE NOTARIZED**

Subscribed and sworn to before me this the

\_\_\_\_\_ day of \_\_\_\_\_, 20\_\_\_\_\_.

\_\_\_\_\_

Signature of Notary Public

**NOTARY SEAL**

of \_\_\_\_\_ County.

State of \_\_\_\_\_

My Commission Expires: \_\_\_\_\_

**EXECUTION OF BID**

**NON-COLLUSION AFFIDAVIT, DEBARMENT CERTIFICATION AND GIFT BAN CERTIFICATION**

**INDIVIDUAL DOING BUSINESS IN HIS OWN NAME**

The person executing the bid, on behalf of the Bidder, being duly sworn, solemnly swears (or affirms) that neither he, nor any official, agent or employee of the bidder has entered into any agreement, participated in any collusion, or otherwise taken any action which is in restraint of free competitive bidding in connection with any bid or contract, that the bidder has not been convicted of violating *N.C.G.S. § 133-24* within the last three years, and that the Bidder intends to do the work with its own bonafide employees or subcontractors and is not bidding for the benefit of another contractor.

In addition, execution of this bid in the proper manner also constitutes the Bidder's certification of status under penalty of perjury under the laws of the United States in accordance with the Debarment Certification attached, provided that the Debarment Certification also includes any required statements concerning exceptions that are applicable.

*N.C.G.S. § 133-32* and Executive Order 24 prohibit the offer to, or acceptance by, any State Employee of any gift from anyone with a contract with the State, or from any person seeking to do business with the State. By execution of any response in this procurement, you attest, for your entire organization and its employees or agents, that you are not aware that any such gift has been offered, accepted, or promised by any employees of your organization.

**SIGNATURE OF CONTRACTOR**

Name of Contractor \_\_\_\_\_  
Print or type Individual Name

\_\_\_\_\_  
Address as Prequalified

\_\_\_\_\_  
Signature of Contractor, Individually

\_\_\_\_\_  
Print or type Signer's name

\_\_\_\_\_  
Signature of Witness

\_\_\_\_\_  
Print or type Signer's name

**AFFIDAVIT MUST BE NOTARIZED**

Subscribed and sworn to before me this the  
\_\_\_\_\_ day of \_\_\_\_\_, 20\_\_\_\_\_.

\_\_\_\_\_  
Signature of Notary Public

**NOTARY SEAL**

of \_\_\_\_\_ County.

State of \_\_\_\_\_

My Commission Expires: \_\_\_\_\_

## DEBARMENT CERTIFICATION

Conditions for certification:

1. The prequalified bidder shall provide immediate written notice to the Department if at any time the bidder learns that his certification was erroneous when he submitted his debarment certification or explanation filed with the Department, or has become erroneous because of changed circumstances.
2. The terms *covered transaction, debarred, suspended, ineligible, lower tier covered transaction, participant, person, primary covered transaction, principal, proposal, and voluntarily excluded*, as used in this provision, have the meanings set out in the Definitions and Coverage sections of the rules implementing Executive Order 12549. A copy of the Federal Rules requiring this certification and detailing the definitions and coverages may be obtained from the Contract Officer of the Department.
3. The prequalified bidder agrees by submitting this form, that he will not knowingly enter into any lower tier covered transaction with a person who is debarred, suspended, declared ineligible, or voluntarily excluded from participation in NCDOT contracts, unless authorized by the Department.
4. For Federal Aid projects, the prequalified bidder further agrees that by submitting this form he will include the Federal-Aid Provision titled *Required Contract Provisions Federal-Aid Construction Contract (Form FHWA PR 1273)* provided by the Department, without subsequent modification, in all lower tier covered transactions.
5. The prequalified bidder may rely upon a certification of a participant in a lower tier covered transaction that he is not debarred, suspended, ineligible, or voluntarily excluded from the covered transaction, unless he knows that the certification is erroneous. The bidder may decide the method and frequency by which he will determine the eligibility of his subcontractors.
6. Nothing contained in the foregoing shall be construed to require establishment of a system of records in order to render in good faith the certification required by this provision. The knowledge and information of a participant is not required to exceed that which is normally possessed by a prudent person in the ordinary course of business dealings.
7. Except as authorized in paragraph 6 herein, the Department may terminate any contract if the bidder knowingly enters into a lower tier covered transaction with a person who is suspended, debarred, ineligible, or voluntarily excluded from participation in this transaction, in addition to other remedies available by the Federal Government.

## DEBARMENT CERTIFICATION

The prequalified bidder certifies to the best of his knowledge and belief, that he and his principals:

- a.** Are not presently debarred, suspended, proposed for debarment, declared ineligible, or voluntarily excluded from covered transactions by any Federal department or agency;
- b.** Have not within a three-year period preceding this proposal been convicted of or had a civil judgment rendered against them for commission of fraud or a criminal offense in connection with obtaining, attempting to obtain, or performing a public (Federal, State or local) transaction or contract under a public transaction; violation of Federal or State antitrust statutes or commission of embezzlement, theft, forgery, bribery, falsification or destruction of records; making false statements; or receiving stolen property;
- c.** Are not presently indicted for or otherwise criminally or civilly charged by a governmental entity (Federal, State or local) with commission of any of the offenses enumerated in paragraph b. of this certification; and
- d.** Have not within a three-year period preceding this proposal had one or more public transactions (Federal, State or local) terminated for cause or default.
- e.** Will submit a revised Debarment Certification immediately if his status changes and will show in his bid proposal an explanation for the change in status.

If the prequalified bidder cannot certify that he is not debarred, he shall provide an explanation with this submittal. An explanation will not necessarily result in denial of participation in a contract.

Failure to submit a non-collusion affidavit and debarment certification will result in the prequalified bidder's bid being considered non-responsive.

Check here if an explanation is attached to this certification.

**Contract No: 11-02-514**

**County: Watauga**

ACCEPTED BY THE  
DEPARTMENT OF TRANSPORTATION

---

Contract Officer

---

Date

